

THREE PHASE INDUCTION MOTOR

OUTLINE DIMENSIONS

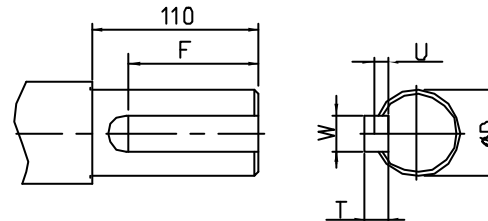
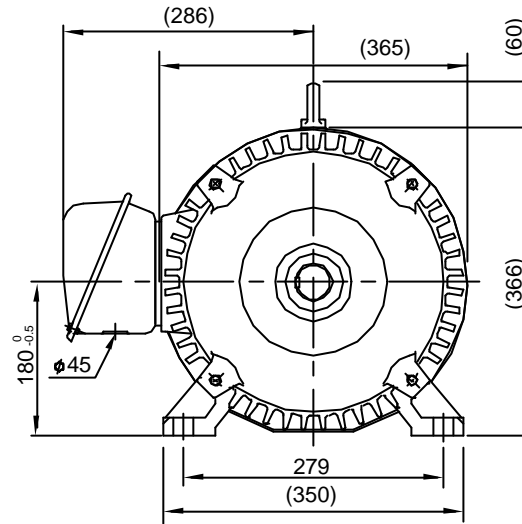
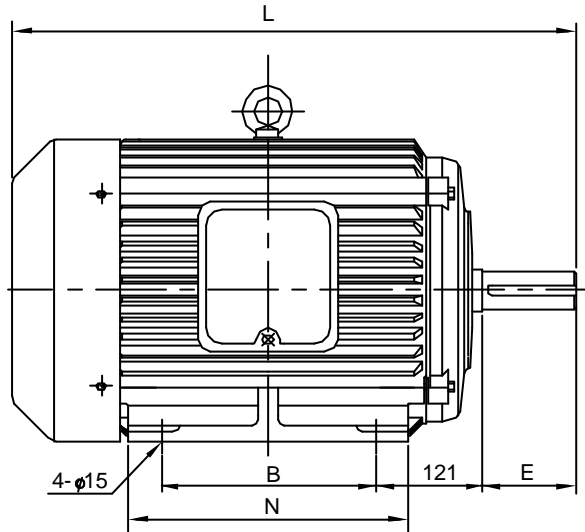

SHAFT EXTENSION

OTHER SPECIAL FEATURES

1. CAST IRON FRAME AND END BRACKETS.
2. STAINLESS STEEL NAME PLATE WITH CONNECTION DIAGRAM.
3. STEEL FAN COVER AND TERMINAL BOX.

NOTE

1. 3 PHASE SQUIRREL CAGE INDUCTION MOTOR
2. TYPE : TOTALLY ENCLOSED FAN COOLED, FOOT-MOUNTED MOTOR.
3. ALL DIMENSIONS ARE IN MILLIMETERS.
4. THE TOLERANCE FOR THE CENTER HEIGHT : $(-\frac{0}{0.5})$
5. THE TOLERANCE FOR THE KEY DIMENSIONS IS IN ACCORDANCE WITH KS B 1311-84

DRAWING NO.		
PREPARED	CHECKED	APPROVED
'00.07.28 K.J. HA	'00.07.28 H.T. KIM	'00.17.28 J.H. KIM

FRAME NO.	OUTPUT(KW)				DEGREES OF PROTECTION	RATING	L	E	F	B	N	φ D	W	T	U
	2P	4P	6P	8P											
180M	22	18.5/22	15	11	IP44	CONT.	645	110	98	241	280	48k6	14	9	5.5

LG·OTIS