

SINGLE PHASE INDUCTION MOTOR

OTHER SPECIAL FEATURES

1. STEEL FRAME AND CAST END BRACKETS.
2. () DIMENSIONS ARE REFERENCE

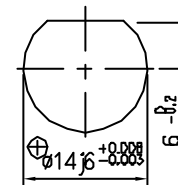
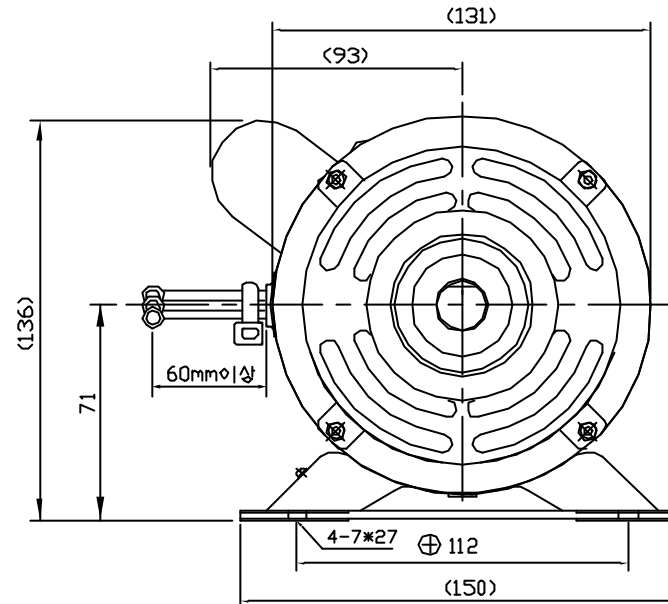
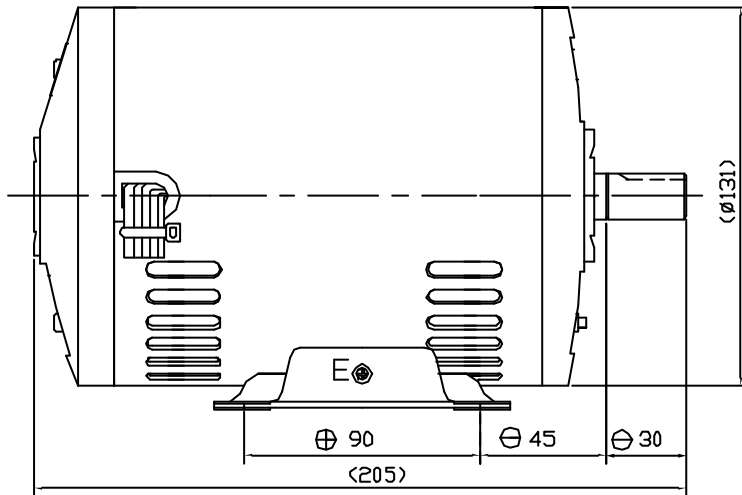

SHAFT EXTENSION

NOTE>

1. 1 PHASE SQUIRREL CAGE INDUCTION MOTOR
2. ALL DIMENSIONS ARE IN MILLIMETERS
3. PAINT COLOR : GRAY
4. TYPE : ODP HORIZONTAL TYPE

GENERAL SPECIFICATIONS

NO	FRAME NO.	HP	POLE	VOLTS	HZ	INS. CLASS	SERVICE FACTOR	RATING	BEARING		APPROX. WEIGHT	PROTECTION	MODEL NAME
									DRIVE	OPP.DRIVE			
A	71	1/8	4	220	60	B	1.0	CONT.	6202ZZ	6202ZZ	7.6KG	IP22	KMT-100B6
B													
C													
D													

DRAWING NO.

PREPARED	CHECKED	APPROVED
2000.10.6 CH CHØ	2000.10.7 H.K. KIM	2000.10.7 H.K. KIM

LG·OTIS