

SINGLE PHASE INDUCTION MOTOR

TYPE \Rightarrow **OPEN DRIP PROOF**

OTHER SPECIAL FEATURES

OUTLINE DIMENSIONS

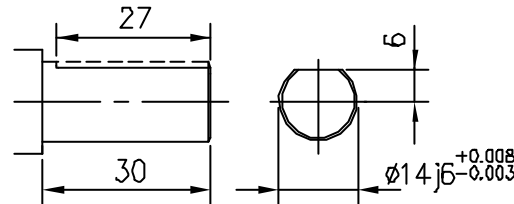
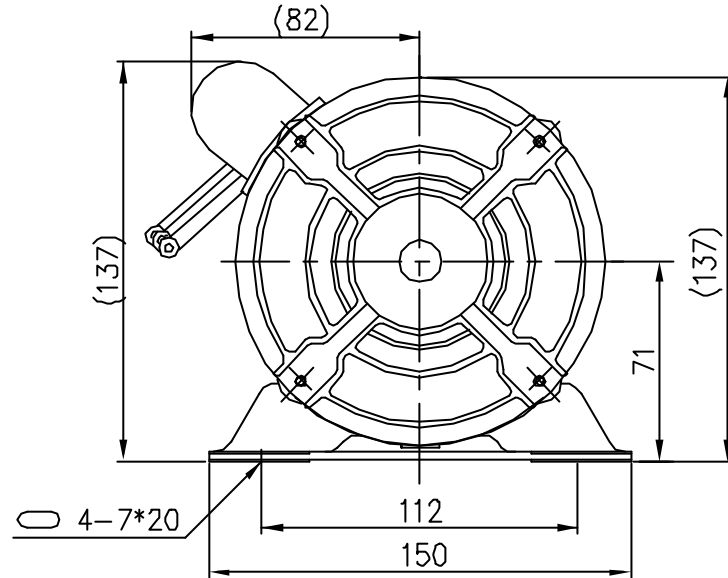
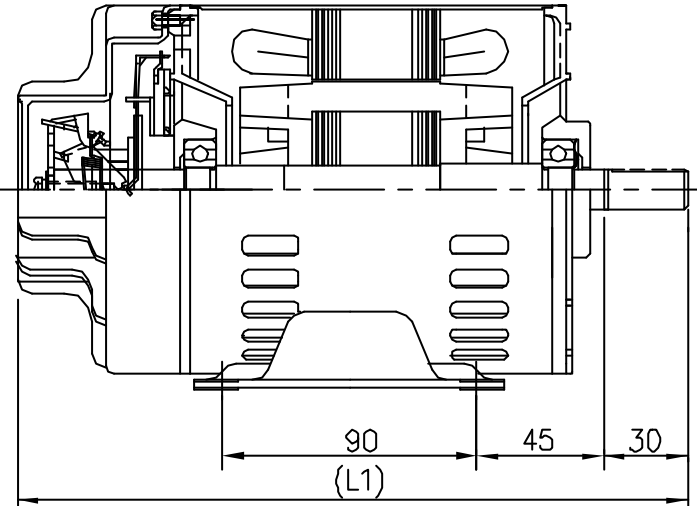

SHAFT EXTENSION

1. STEEL FRAME AND CAST END BRACKETS.
2. () DIMENSIONS ARE REFERENCE

NOTE>

1. SINGLE PHASE SQUIRREL CAGE INDUCTION MOTOR
2. ALL DIMENSIONS ARE IN MILLIMETERS
3. PAINT COLOR : BLUE
4. TYPE : ODP HORIZONTAL TYPE

GENERAL SPECIFICATIONS

NO.	FRAME	KW	POLE	VOLTS	HZ	INS. CLASS	SERVICE FACTOR	BEARINGS		APPROX. WEIGHT	PROTECTION	L1	MODEL NAME
								DRIVE	OPP.DRIVE				
A	71	0.2	4	220	60	B	1.0	6202ZZ	6202ZZ	6.4 kg	IP22	238	KMT-200B7
B													
C													
D													

DRAWING NO.		
PREPARED	CHECKED	APPROVED
2000.05.13 CH CHO	2000.05.13 KIM HOKI	2000.05.13 KIM HOKI

LG-OTIS